

MAP 17

MAP 17

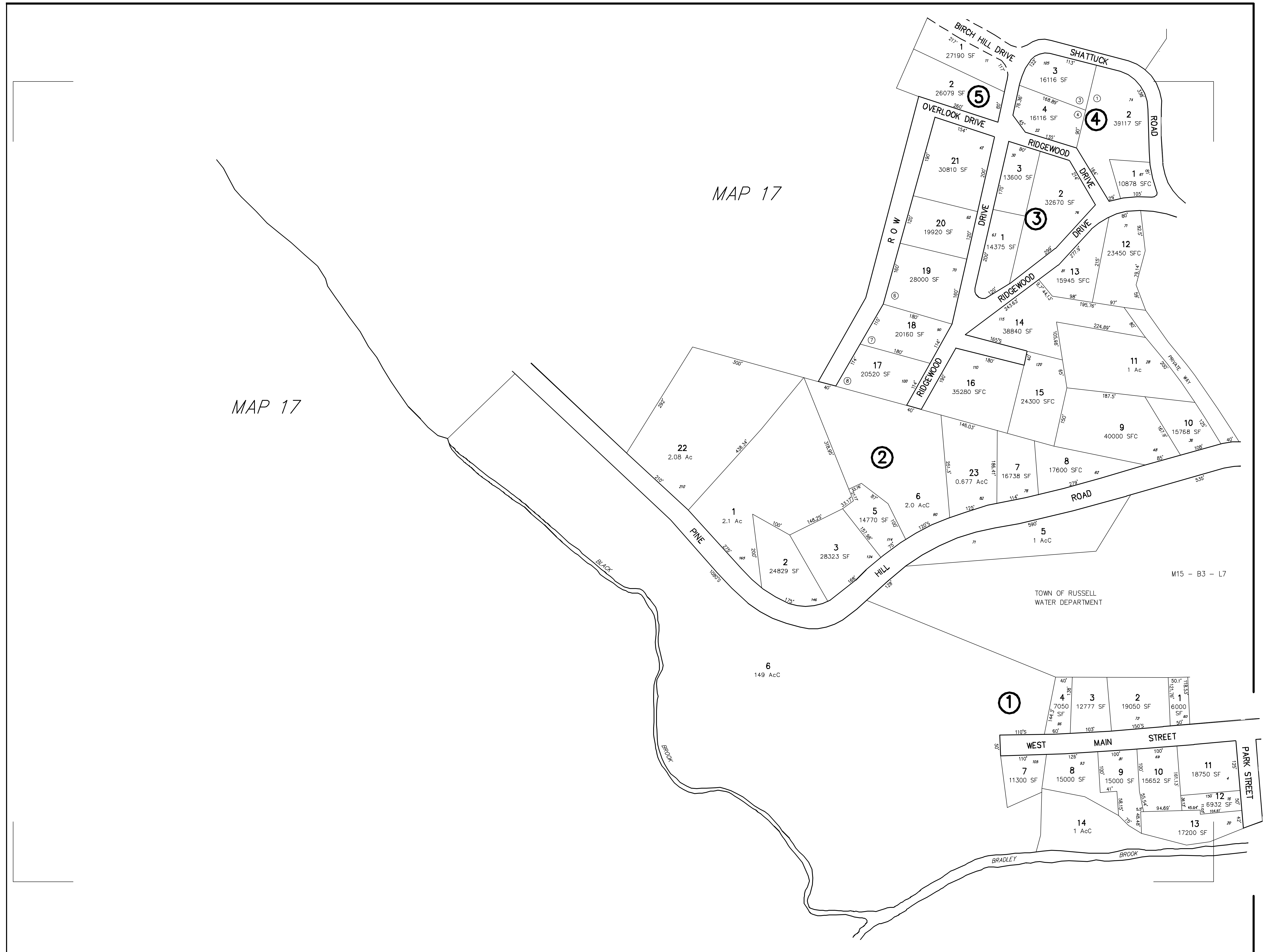

M15 - B3 - L7

TOWN OF RUSSELL
WATER DEPARTMENT

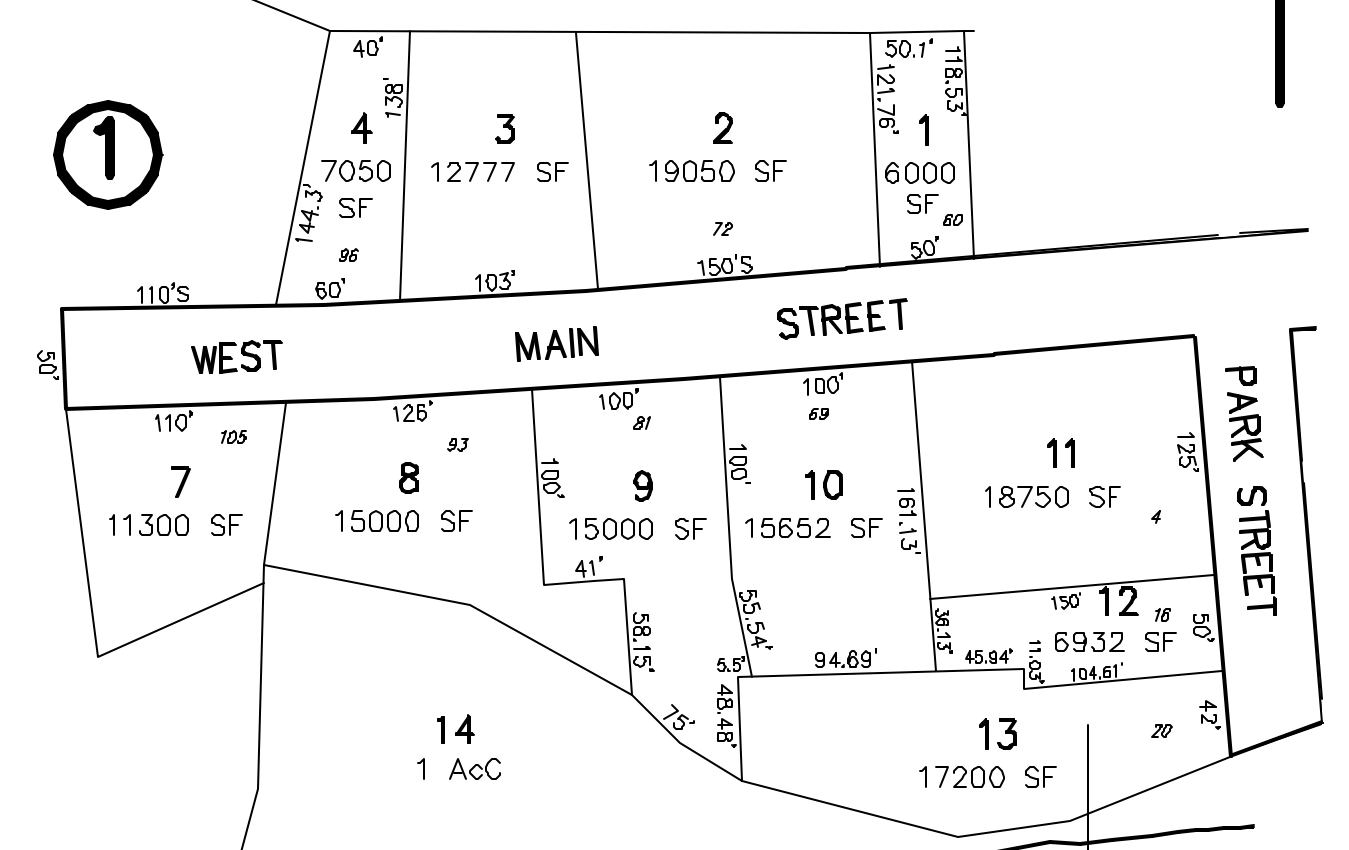

THIS MAP IS FOR ASSESSMENT PURPOSES. IT IS NOT VALID FOR LEGAL DESCRIPTION OR CONVEYANCE.
THE HORIZONTAL DATUM IS THE MASSACHUSETTS STATE PLANE COORDINATE SYSTEM, NAD 83.
ORIGINAL MAPS PREPARED UNDER THE DIRECTION OF THE RUSSELL BOARD OF ASSESSORS, BY AVIS AIRMAP, INC.

DIGITIZED IN 2009 BY
CARTOGRAPHIC ASSOC. INC.
PROFESSIONAL GIS CONSULTANTS
MUNICIPAL MAPPING - GIS - PUBLIC WORKS INFORMATION MANAGEMENT
11 PLEASANT STREET, LITTLETON, NEW HAMPSHIRE 03561
(603)444-6768 - (603)322-4540 - FAX (603)444-1366 - WWW.CAI-INFO.COM

LEGEND

AREA SURVEYED Ac/SF	STREET NUMBER 000
AREA CALCULATED Ac/SFC	SUBDIVISION LOT NO. ②
RECORD DIMENSION 100'	RIGHT OF WAY/ACCESS ③
SCALED DIMENSION 100'S	BLOCK NUMBER ④
WATER	COMMON OWNERSHIP ⑤
	WETLANDS

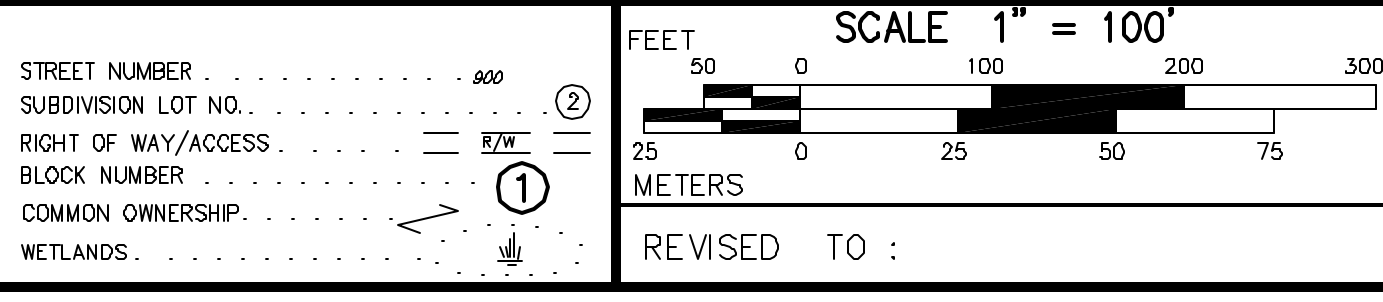

PROPERTY MAPS
RUSSELL
MASSACHUSETTS

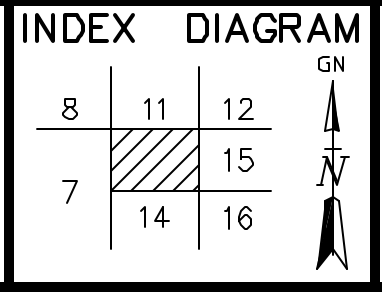

MAP NO.
13